



Client _____ Quantity _____

Project _____ Position _____

FUN 700

Model: F70/40FTE/CR/P

Cod: MP01372123023

Technical data

Modularity:	On cabinet with door
Dimension (mm):	400x700x850
Total electric power (kW):	4,5
Cooking zone dimensions 1 (LxD mm):	396x520
Electric power (V):	380-415
Ampere (A):	7
Phases:	3N
Cable section (mmq):	5G1,5
Frequency (Hz):	50-60
Net volume (m3):	0,238
Packing dimensions (mm):	477x776x1147
Gross weight (kg):	60
Gross volume (m3):	0,425

Features

Working top:	Made of AISI 304 stainless steel with a thickness of 10/10 mm
Material of plate:	Polished chrome
Plate finish:	Ribbed
Knobs:	Knobs are made from a sturdy heat-resistant polymer blend and are equipped with liquid anti-leakage washer
Handles:	Brushed aluminum finish
Plate:	Polished chromed plate

Technical draw

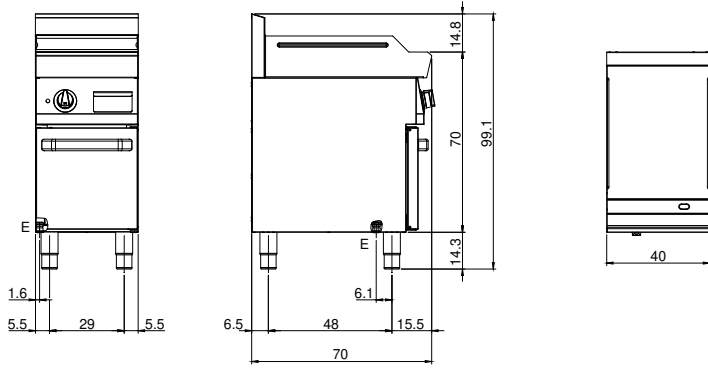

E: Electric power