

# Reach-In Blast Chiller / Shock Freezer MultiFresh Model MF 45.1L

## MF 45.1L-MYA

... YOUR TRUSTED KITCHEN ASSISTANT

The **IRINOX Model MF 45.1L Blast Chiller / Shock Freezer** shall have the following characteristics: Capacity – (8) 18"x26" full size sheet pans or (16) 12"x20"x2-1/2" steam table pans; controller - shall feature the following control paths: standard mode for chilling or freezing, dynamic mode for chilling or freezing (icon driven) and personalized modes for customer specific products; core probe - multi-sensor product core temperature probe with five (5) measuring points and "easy-out" feature; plus all the standard features listed below.



Item No.	_____
Qty.	_____
Project	_____
	_____
	_____
	_____

### Standard Construction Features:

- (4) stainless steel wire shelves
- All type 304 stainless steel construction
- CFC-free high-density polyurethane insulation
- Full width door with low-temperature resistant magnetic gasket
- Die-stamped interior door liner to magnetically store core probe
- Ergonomic edge-free stainless steel door handle
- Removable stainless steel pan supports, adjustable spacing
- Approved 404A refrigerant used in sealed system
- High efficiency evaporators with multiple injection points
- Magnetic lock front grille and magnetic coil filter for easy condenser cleaning
- Luminous display with intuitive work-path controls
- Thawing cycle and proofing cycle
- Door hinged left (standard)
- 4" stainless steel height-adjustable legs
- End-of-cycle hold mode
- Air-cooled, self-contained energy efficient condensing unit

### Sizing & Unit Production Guide MF 45.1L

Capacity: (12"x20"x2-1/2") steam table pans	16
Capacity: (18"x26") full size sheet pans	8
Pan Spacing:	adjustable
Blast Chilling Capacity (194F to 37F)*:	100 lbs
Shock Freezing Capacity (194F to 0F)*:	100 lbs
* Per production cycle (depending on product density): Blast chilling ... up to 90-minute cycle Shock freezing ... up to 240-minute cycle	

### Unique Design and Performance Features:

- 4 Standard cycles, 112 product specific cycles; ability to record up to 38 replicable cycles
- Electronically controlled fans with automatic speed variation, low power consumption; open-door auto stop feature
- Indirect air distribution and special airflow pattern to ensure perfect temperature uniformity
- Easy access to clean evaporators, waterproof fans, and removable magnetic condenser filter
- Easy to use touch screen with 7" interface
- Low temperature cooking, thawing, proofing, regeneration, pasteurization, holding and chocolate melting cycles
- WIFI for data transfer to HACCP software
- Core probe magnetically secured to door when not in use

### Options and Accessories (Please check):

- Sous-vide pouch core temperature probe
- Prison package
- Door hinged right
- (4) swivel casters, two (2) with locks
- SANIGEN sanitation system
- Remote, air-cooled condensing unit
- Self-contained, water cooled condensing unit
- Liquid probe holder
- 2 Additional food probes
- Additional stainless steel wire shelves

### Product Warranty Protection:

- 1 year, parts and labor
- 5 year, compressor

Operating Modes:	Temperature Drop (F)*	Time **	Product Applications:
Standard Mode – Delicate to +37F	+194F to +37F	90 min or less	Delicate or thin food items
Standard Mode – Strong to +37F	+194F to +37F	90 min or less	High density, bulky or packaged food items
Standard Mode – Delicate to 0 F	+194F to 0 F	240 min or less	Hot cooked food items
Standard Mode – Strong to 0 F	+194F to 0 F	240 min or less	Raw, chilled or thin cooked food items
Dynamic Mode (Icon Driven) to +37F	+194F to +37F	Set times***	Specific product categories
Dynamic Mode (Icon Driven) to 0 F	+ 194 F to 0 F	Set times***	Specific product categories

\* Core product temperature \*\* Actual times based on product density \*\*\* Actual times set by Icon Product Code



IRINOX USA

Phone: 508-230-5818 Fax: 508-230-5819 www.irinoxusa.com email: info@irinoxusa.com

# MF 45.1L-MYA

**... YOUR TRUSTED KITCHEN ASSISTANT**

HEIGHT	
a	b
63"	4-1/2-6-1/2"

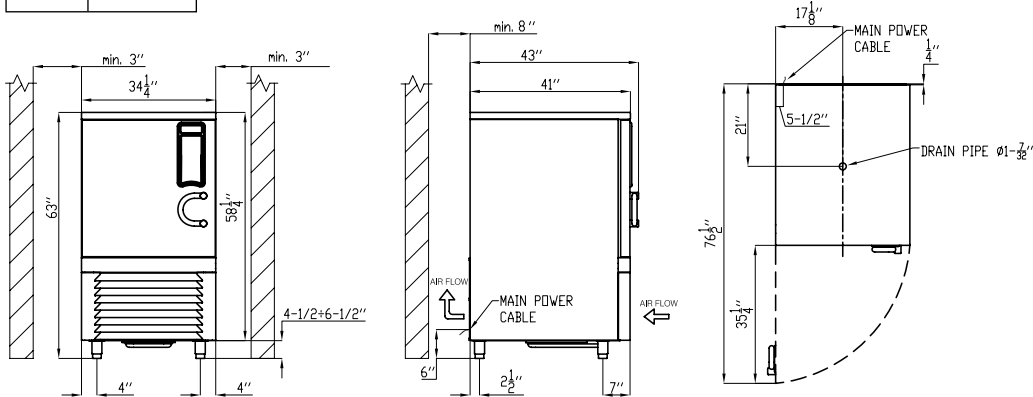

<b>Equipment Dimensions and Weight</b>	
Width	34-1/4"
Depth	43"
Height w/legs not extended	63"
Height w/casters	64"
Weight	540 lbs
Capacity: (12"x20"x2-1/2") steam table pans – adjustable pan spacing	16
Capacity: (18"x 26")full size sheet pans – adjustable pan spacing	8

**Installation Notes:**  
 1. Compressor requires 8" minimum rear wall clearance and 3" right and left clearance

<b>Key Refrigeration System Data</b>	
Compressor rating (HP)	2.75
Refrigeration Yield (14/+104F) (BTU/HR)	24,644
Condenser Yield (14/+104F) (BTU/HR)	37,697
Refrigerant Type / Nominal Refrigerant Charge (lbs)	R404A / 8.2
Maximum Ambient Temperature (F)	90

[D] Drain Connection: 1-1/4" ID [Per local codes]

<b>Electric Data / Power Requirements</b>	
208V 60 Hz 3 Phase	Total Rating: 4.5 KW
208V 60 Hz 3 Phase	Amp Draw: 12.6 A
NEMA Plug Configuration	L15-20P

Continued product development may necessitate specification changes without notice.



Rev. 09/14



IRINOX USA  
 Phone: 508-230-5818 Fax: 508-230-5819 www.irinoxusa.com email: info@irinoxusa.com