



HOSHIZAKI



- > **FM-150KE**
 - > **FM-150KE-50**
- flake ice**

daily ice production capacity of up to 150kg



- > **FM-150KE-N**
 - > **FM-150KE-50-N**
- nugget ice**

daily ice production capacity of up to 140kg



> FM-150KE-50



> FM-150KE

Aside for drinks, ice is important for preservation purposes. Hoshizaki's FM ice machines produce flakes consisting of 70% ice and 30% water, used primarily for cooling purposes and has no 'freeze-burn' effect when displaying fresh produce. It is also used in large facilities such as healthcare, catering, supermarket chains or even cocktail bars.

FEATURES

- > carbon auger bearings enhances product life expectancy, reduces maintenance cost
- > hydrocarbon refrigerants lowers energy consumption
- > 100% hfc free co2 foam insulation maintains consistent temperature
- > smart computer board technology
- > stainless steel exterior
- > led error indicator for easy diagnosis
- > self-contained unit



UNIQUE ICE PRODUCTION SYSTEM



FLAKE ICE MAKER SERIES

FLAKE ICE MAKER AIR SYSTEM FM-150KE & FM-150KE-N

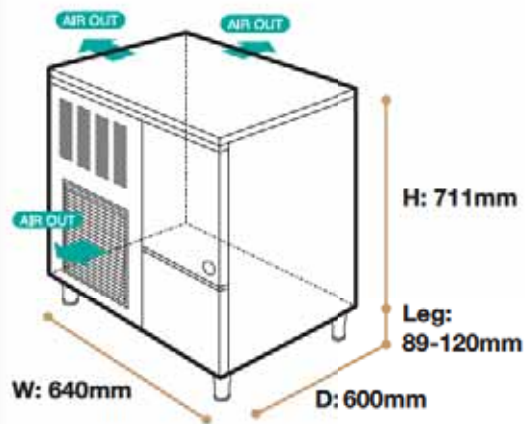

TOP VIEW

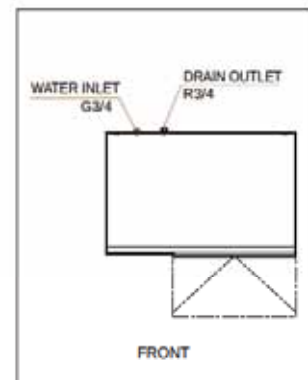

FLAKE ICE MAKER AIR SYSTEM FM-150KE-50 & FM-150KE-50-N

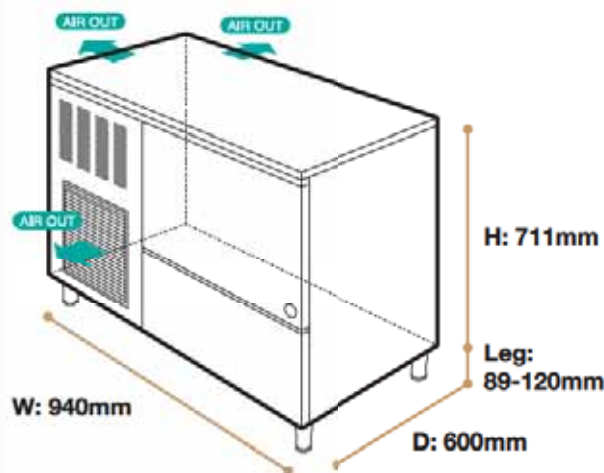

TOP VIEW

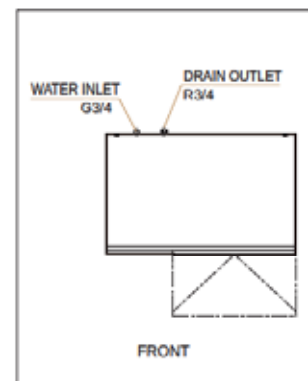

MODEL NAME	FM-150KE	FM-150KE-N	FM-150KE-50	FM-150KE-50-N	
ICE SHAPE	Flake	Nugget	Flake	Nugget	
DIMENSIONS (MM) (W x D x H)	Body : 640 x 600 x 711 / Leg Height : 89-120 mm		Body : 940 x 600 x 711 / Leg Height : 89-120 mm		
PACKED DIMENSIONS (MM) (W x D x H)	746 x 706 x 887		1046 x 706 x 887		
WEIGHT (NETT/GROSS)	71 KG / 82 KG		81 KG / 94 KG		
AMPERAGE / STARTING AMPERAGE	5.1A / 20A				
ELECTRICAL CONSUMPTION	640 W				
REFRIGERANT CHARGE	R134a				
HEAT REJECTION	1120 W (963 kcal/h)				
ICE PRODUCTION PER 24H (15MM)	(AT10°C/WT10°C)	150 KG	140 KG	150 KG	140 KG
	(AT21°C/WT15°C)	130 KG	120 KG	130 KG	120 KG
	(AT32°C/WT21°C)	110 KG	100 KG	110 KG	100 KG
WATER CONSUMPTION PER 24H (AT21°C/WT15°C)	0.130 m ³	0.120 m ³	0.130 m ³	0.120 m ³	
	1L / 1KG ICE	1L / 1KG ICE	1L / 1KG ICE	1L / 1KG ICE	
STORAGE CAPACITY	26 KG	32 KG	57 KG	65 KG	

• WARRANTY:

Two years parts & labour for entire unit, 3rd year on compressor only. Excluding door & exterior damages

OPERATING CONDITIONS: • Voltage Range: 198V-254V • Ambient Temperature: 1°-40°C
• Water Supply: 5°-35°C / 0.05-0.8 Mpa / 7.25-116 PSI • AC Supply Voltage: 1/220-240V / 50 Hz